



Tiger-Vac®

The name to vacuum with...

Cleanroom Mini-Vac Systems ULPA Filtered Efficiency 99.999% @ 0.12 Micron
Light Weight and Easy to Carry



Our smallest Clean Room Vacuum Cleaner. Just 18" (46cm) Long !

Model MV-1 CR (HH) Hand Held, Part No. 110735
Available with shoulder strap Part No. 211607

Weight: 11 lbs. (5 kgs.)
Dimensions: diam. 7.5" x 18" (19 cm x 46 cm)
Recovery capacity (paper filter bag): 0.5 gal (1.9 L)
Detachable power cord length: 35' (10.6 m)

Designed for better mobility and flexibility



Model MV-1 CR (BP) Back Pack
Part No. 110737

- ✓ **Static free (ESD safe).** The Minis are designed to be grounded during use. The electrical resistivity is less than 10 ohms. Any static produced while vacuuming is quickly and effectively discharged to the ground.
- ✓ **Designed for a variety of cleanroom environments and mini environments, including:**
 - Semiconductor / Microelectronic
 - Pharmaceutical
 - Medical / Bio-hazard

Toll free telephone: 1 800 668-4437
Toll free fax: 1 800 668-4439

Web Site: <http://www.tiger-vac.com>

Tiger-Vac International Inc.
2020 Blvd. Dagenais
Laval, Quebec
Canada H7L 5W2
Tel.: (450) 622-0100
Fax.: (450) 625-3388
E-mail: support@tiger-vac.com

Tiger-Vac Inc. (USA)
73 S.W. 12 Ave. Bldg.1. Unit 7
Dania, FL 33004
USA
Tel.: (954) 925-3625
Fax.: (954) 925-3626
E-mail: sales@tiger-vac.com

MINIVAC CLEANROOM VACUUM CLEANER SYSTEMS



Model MV-1 CR (BP)
Back Pack Part No. 110737



Model MV-1 CR (GC)
Golf Cart Part No. 110739

MV-1 (BP): Weight: 14.3 lbs. (6.5 Kg) Vacuum Cleaner Only
Dimensions: Ø 7.5" x 23.5" (19 cm x 60 cm)
Recovery Capacity: paper filter bag 1.5gal. (5.7 L)
Detachable power cord length: 35' (10.6 m)

MV-1 (GC): Weight: 15 lbs. (7 Kg) Vacuum Cleaner Only
Dimensions: Ø7.5" x 23.5" (Ø19 cm x 60 cm)
with handle: H36" (H91 cm)
Recovery Capacity: paper filter bag 1.5gal. (5.7 L)
Detachable power cord length: 35' (10.6 m)

Filtration System for MV-1 CR (BP), MV-1 CR (GC) and MV-1 CR (HH)

4 STAGE FILTRATION SYSTEM

1. PAPER FILTER BAG WITH MICRO-LINER (one micron efficiency): collects the bulk of the recovered materials and keeps the other filters free from clogging. Also allows for easy emptying. Part No. 212230 for MV-1(BP) & (GC) Part No. 212075 for MV-1(HH)
2. CLOTH FILTER (one micron efficiency): This washable main filter prolongs the life of the ULPA filter. Part No. 212232 for MV-1(BP) & (GC) Part No. 211623 for MV-1 CR (HH)
3. DOME FILTER: Protects the motor in the event that filters 1 and 2 are used incorrectly. Part No. 211623 for MV-1(BP) & (GC) Part No. 211623 for MV-1 CR (HH)
4. ULPA FILTER[†]: Minimum efficiency of 99.999% on particles as small as 0.12 micron. Purifies exhaust air and ensures cleanroom compatibility. Part No. 212073

- A. Suction intake with closing valve to prevent spillage
- B. EMI/RFI electronic filter suppressor
- C. Clean air exhaust

** A special filter lined with stainless steel is available for the recovery of broken wafers and sharp objects. Replaces filters 1 and 2. Part No. 213254 for MV-1(BP) & (GC) Part No. 212079 for MV-1 CR (HH)

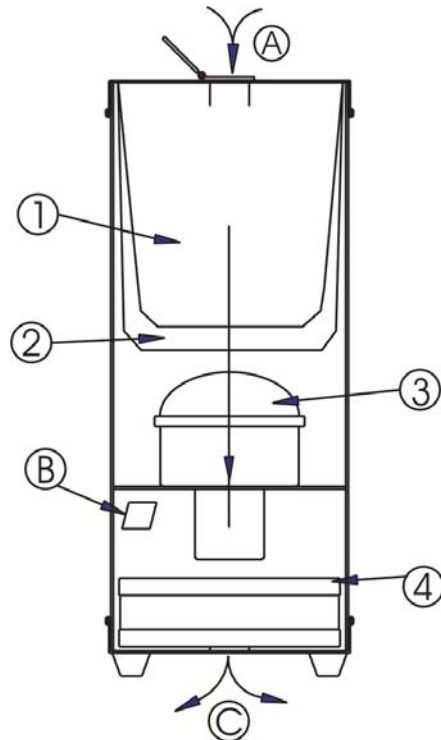



Containment Vacuum Cleaner System Bio-Hazard
With Dual Filtration: HEPA & ULPA Efficiency
Disposable HEPA Filter Collects the Bulk of Toxic Dust
Two Configurations Available: Back Pack (BP) or Golf Cart (GC)



Model: MV-1 CR (CVGC)
 Golf Cart
 Part No. 110748



Model: MV-1 CR (CVBP)
 Back Pack
 Part No. 110744



Containment HEPA Filter:

The HEPA filter[†] cartridge is sealed directly to the lid of the vacuum to ensure absolute leak-free operation. The contaminants trapped in the Containment HEPA filter[†] remain contained during disposal.

Part No. 213260

CVBP:

Weight: 14.3 lbs. (6.5 Kg) Vacuum Cleaner only
 Dimensions: Ø 7.5" x H23.5" (Ø19 cm x H60 cm)

CVCG:

Weight: 15 lbs. (7 Kg) Vacuum Cleaner only
 Dimensions: Ø 7.5" x H23.5" (Ø19 cm x H60 cm)
 with handle: H36" (H91 cm)

Recovery Capacity: 40 oz. (1.2 L)

Detachable power cord length: 35' (10.6 m)

Filtration System for MV-1 CR (CV)

Effectively Collects Hazardous Molds and Viral Particulate, Including: Anthrax Dust, Stachybotrys Colonies, Aspergillus Spores, Penicillium Spores & Allows for Safe and Efficient Disposal of Recovered Materials

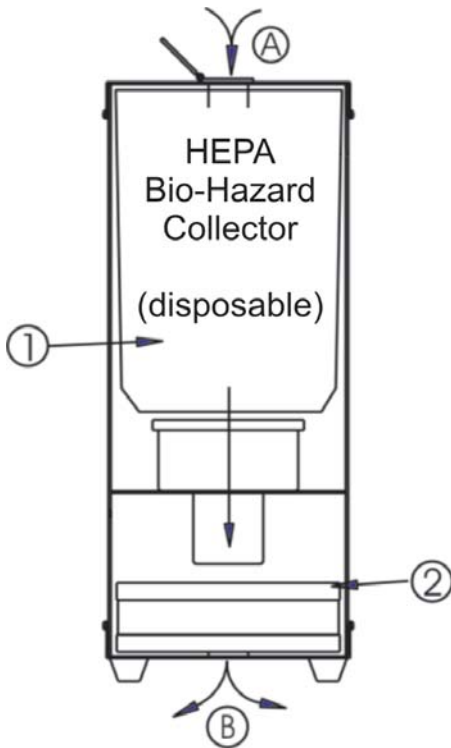

FILTRATION & COLLECTION SYSTEM

1. Containment HEPA filter[†] (disposable):
 Efficiency of 99.99% @ 0.3 micron.
 Size: 11" x 6.25" (28cm x 16cm)
 Recovery capacity: 40 oz (1.2 liters) Part no. 213260
 2. Exhaust ULPA filter[‡] : Minimum efficiency of 99.999% on particles as small as 0.12 micron. Purifies exhaust air and ensures cleanroom compatibility. Part no. 212073
- A. Suction intake with closing sealed valve to prevent spillage
 B. Clean air exhaust, filtered through the ULPA filter[‡].

All recovered material enters the vacuum system through the Containment HEPA filter[†] which immediately captures and contains hazardous molds and viral particulate down to 0.3 micron in size, with a 99.99% efficiency.

In effect, the Containment HEPA filter[†] prevents the vacuum cleaner from becoming contaminated. When full, the Containment HEPA filter[†] is removed and disposed without compromising the integrity of the vacuum system.

The Containment HEPA filter's exclusive loading feature (bottom to top) maximizes holding capacity and maintains airflow.

STANDARD TOOLS & ACCESSORIES (INCLUDED)

- | | | |
|-----|---------|---|
| 1 | 212070 | Static dissipating suction hose
Ø1.25" x 5' (Ø32mm x 1.5m) |
| 2. | 323316 | Micro tool kit SD* |
| 3. | 323312A | Round brush SD* |
| 4. | 323321A | Round tool SD* |
| 5. | 323314A | Flat tool SD* |
| 6. | 323313A | Crevice tool SD* |
| 7. | 211065 | Ground continuity tester |
| 8. | 212230 | Paper filter bags (5/pkg) for MV-1 CR (BP) & (GC) |
| 8a. | 212075 | Paper filter bags (5/pkg) for MV-1 CR (HH) |
| 9. | 212080 | Detachable power cord 35' (10.6m) |
| | 212081 | Detachable power cord European plug |
| | 212082 | Detachable power cord UK plug |
| | 212083 | Detachable power cord Swiss plug |



OPTIONAL TOOLS & ACCESSORIES

- | | | |
|-----|---------|--|
| 10. | 212072 | Static dissipating suction hose Ø1.25" x 10'
(Ø32mm x 3m) |
| 11. | 323331 | Wands (2), stainless steel SD* |
| 12. | 323317A | Utility floor and wall tool SD* |
| 13. | 323311B | Combi floor tool |
| 14. | 211066 | Micro Pad |

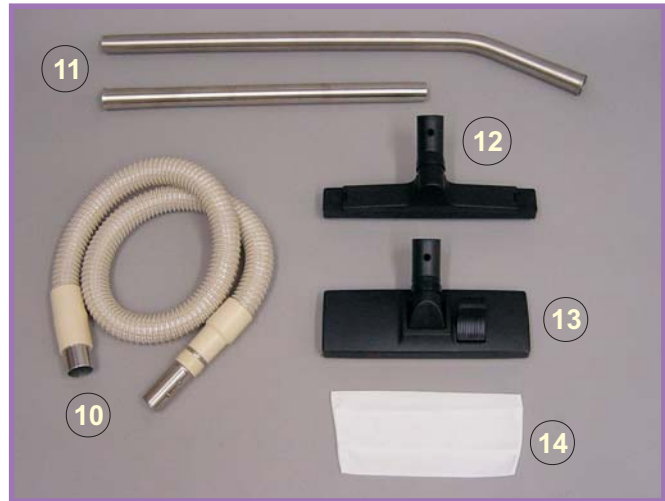

Static Dissipating Micro Tools (Stainless Steel Accessories)

- | | | |
|-----|---------|--|
| 15. | 200001C | Single Operator Attachment Kit (not shown) |
| 16. | 200002C | Double Operator Attachment Kit |
| 17. | 200003 | Straight Tip Micro Crevice Tool |
| 18. | 200004 | Curved Tip Micro Crevice Tool |



For additional tools and accessories please contact one of our Customer service representatives.

*SD: Static Dissipating

†HEPA: High Efficiency Particulate Air

‡ULPA: Ultra Low Penetration Air

All MV-1 CR Models:



Voltage:	120 V	or	240 V
Current Draw:	6.5 amps		4 amps
Airflow:	110 CFM		55 L/second
Vacuum Pressure:	63" H ₂ O		1.8m H ₂ O
Noise Level:	64 dB(A) at 6.5 feet (2 meters)		